ATX12V PC Power Specifications

Model: HK560-11UEP

File No.: 试产

Prepared by: Wei Jun Deng

Checked by: LieYang Zhao

Approved by: Zhi Wu

Date: 2018.04.03

Issue date: 2018.04.03

ECN List

Item	Spec. REV	Revise date	Revise description	Reason
------	-----------	-------------	--------------------	--------

1	00	2018.04.03		
2				
3				
4				
5				
6				
7				
8				
9				
10				
11				
12				
13				

HK560-11UEP 性能规格书

Content 规格书正文

1.0 Input Characteristics 3

1.1 Input Voltage Range

1.2 Input Frequency Range

1.3 Input current

1.4 Inrush current

1.5 Power Efficiency

1.6 Harmonic Current

2.0 Output specification description 3

2.1 Static output characteristics

2.2 Cross-load regulation	
2.3 Dynamic Load	
2.4 Capacitive Load	
2.5 Output connector	
3.0 Protection	5
3.1 Over Voltage Protection	
3.2 Short Circuit Protection	
3.3 Reset after shutdown:	
4.0 Time Sequence	6
4.1 Power-on time	
4.2 Rise Time	
4.3 PWR_OK delay	
4.4 PWR_OK Rise	
4.5 AC loss to PWR_OK hold-up time	
4.6 Power OK	
4.7 PS_ON	
5.0 Auxiliary Output	7
6.0 Environment	8
6.1 Operating ambient:	
6.2 Shipping and Storage:	
6.3 Altitude:	
6.4 Cooling	
7.0 Safety and EMC	8
7.1 SAFETY REQUIREMENTS AND Certify	
7.2 Conducted and Radiated Emissions	
7.3 ESD	
7.4 EFT	
7.5 Surge Susceptibility	
7.6 Hi-Pot	
7.7 Grounding Continuity Test	
7.8 Ground Leakage Current:	

8.0 Mechanical 9

8.1 Mechanical outline&DC wire drawing

8.2 Label drawing

1.0 Input Characteristics:

1.1 Input Voltage Range:

90Vac to 132Vac and 180Vac to 265Vac, single phase.

Table1. Input Voltage Range

RANGE	MINIMUM	NORMAL	MAXIMUM	UNITS
Low Range	90	100~120	132	Vrms
High Range	180	200~240	265	Vrms

1.2 Input Frequency Range:

50+/-3Hz and 60+/-3Hz; Normal Frequency Range: 50-60Hz

1.3 Input current

Max Input AC current: 7 Amp R.M.S max@115Vac full loads; 4Amp R.M.S max@230V .full load.

1.4 Inrush current:

Power supply inrush current shall be less than the ratings of its critical components (including bulk rectifiers, fuses, and surge limiting device) under all conditions of line voltage of Section 1.1.

1.5 Power Efficiency:

Min 82% efficiency under 20% full load condition, input Voltage: 115Vac/60Hz or 230Vac/50Hz

Min 85% efficiency under 50% full load condition, input Voltage: 115Vac/60Hz or 230Vac/50Hz

Min 82% efficiency under 100%full load condition, input Voltage: 115Vac/60Hz or 230Vac/50Hz

1.6 Harmonic Current:

(1) The harmonic of the power line and neutral current shall comply the standard IEC61000-3-2 for class D equipment .

(2) Measurement shall be performed at 75W input power and full output load , Input voltage shall be 115Vac/60Hz or 230Vac/60Hz, Don't test in process under low range.

2.0 Output Characteristics:

2.1 Static output characteristics:

Table2. Static output characteristics

Output Voltage	Load			Regulation	Ripple & Noise
	Min	Max	Surge		Max mV P-P
+5V	0.5A	20A	/	+/- 5%	50mV
+12V	1.0A	38A	/	+/- 5%	120mV
+5VSb	0.1A	3A	/	+/- 5%	50mV
+3.3V	0.5A	15 A	/	+/- 5%	50mV
-12V	0A	0.5A	/	+/- 5%	120mV

At 25°C

(1) The total combined 3.3V/5V power shall not exceed 140W.

(2) The continuous output power shall not exceed 460W.

At50°C

(1) The total combined 3.3V/5V power shall not exceed 120W.

(2) The 5V current shall not exceed 15A.

(3) The continuous output power shall not exceed 415W.

2.2 The cross-load regulation in defined in the matrix below (UNIT: A)

Table 3.Cross Regulation

Range	+5V	+12V	-12V	+3.3V	+5Vsb
1	0.5	1	0.0	0.5	0

2	0.5	7	0.1	0.5	0.5
3	6	15.6	0.15	2	1
4	8	33.5	0.3	3	0.5
5	0.5	37.5	0.5	0.5	0
6	20	1	0.1	1	3
7	1	1	0.15	15	3

Notes: A 0.1uF and 10uF tantalum capacitors should be put across output terminals during ripple & noise test. The oscilloscope bandwidth is set at 20 MHz and co-axial probe will be used to measure it.

2.3 Dynamic Load:

The following transient loads are to be applied to the output.

The waveform shall be a square wave with the slope of the rise and fall at 0.5 A/μs.

The square wave shall have a frequency 50Hz to 10KHz with a duty cycle of 10 to 90%.

The output voltages shall not exceed regulation limits as defined in Table 2 under the following condition:

TRANSIENT VOLTAGE TOLERANCE

Table4. Dynamic Load Step Sizes

NOM. OUTPUT VOLTAGE (VDC)	CURRENT I _{min}	CURRENT I _{max}	STEP LOAD CHANGE (%)	TRANSIENT TOLERANCE (%)
+5.0	0.5A	20A	30	±5
+12.0	1.0 A	38A	40	±5
+3.3	0.5 A	15 A	30	±5

(Adding external capacitor: 5V/6000uF, 12V/10000uF, 3.3V/6000uF, -12V/350uF, 5Vaux/350uF)

2.4 Capacitive Load:

The power supply should be able to power up and operate with the regulation limits defined in Table 2, with the following capacitances simultaneously present on the DC outputs.

Table5. Output Capacitive Loads

Output	Capacitive Load
--------	-----------------

+12V	10000 μ F
+5V	6000 μ F
+3.3V	6000 μ F
-12V	350 μ F
+5VSb	350 μ F

2.5 The power supply shall have the output connector and wire harness configurations.

3.0 Protection

3.1 Over Voltage Protection:

+5V:7.0V max,+12V: 15.6V max +3.3V 4.7V max.

3.2 Short Circuit Protection:

The power supply shall shut down and latch off for shorting +5V,+12V,-12V or +3.3V rails to DC-return and shorting.

3.3 Reset after shutdown:

When the power supply latches into shutdown condition due to a fault on an output(over current,over voltage or short circuit),the protection latch shall reset within 30S after the fault has been removedand the ON/Off signal has switched state. Also,the latch shall reset within 30S when AC power has been removed.

4.0 Time Sequence

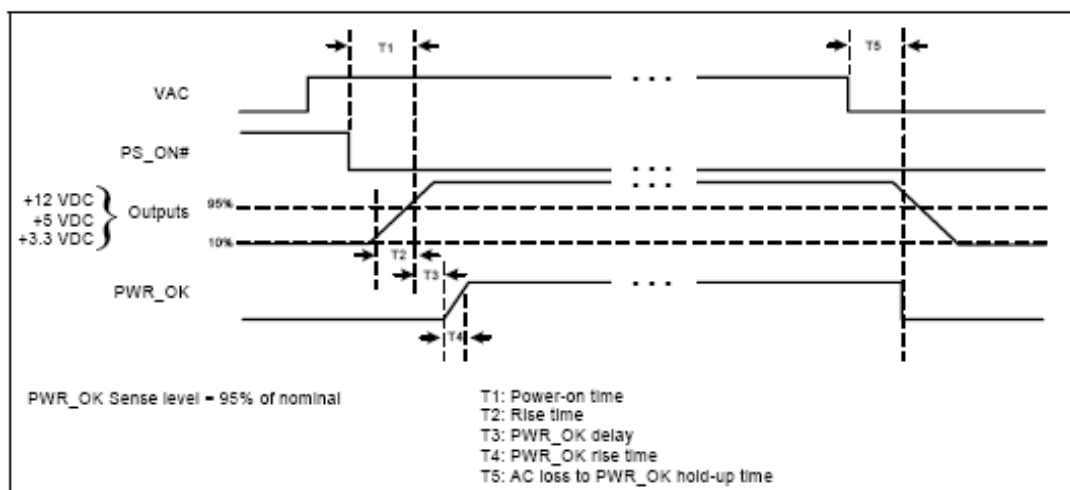

4.1 Power-on time T1

The power-on time is defined as the time from when PS_ON# is pulled low to when the +12 VDC, +5 VDC, and +3.3 VDC outputs are within the regulation ranges specified in Section 2.1. The power-on time shall be less than 500 ms ($T1 < 500$ ms).

4.2 Rise time T2

The output voltages shall rise from $\leq 10\%$ of nominal to within the regulation ranges specified in Section 2.1 within 0.1 ms to 20 ms ($0.1 \text{ ms} \leq T2 \leq 20 \text{ ms}$).

4.3 PWR_OK delay T3

The Power Good signal shall have a turn-on delay of at least 100mS but not greater than 500 mS from the time the 3.3V and +5V output has reached their minimum regulation level.

4.4 PWR_OK rise time T4

The Power Good signal shall have a rise time (measured from the 10% point to the 90% point) of less than 10 milliseconds.

4.5 AC loss to PWR_OK hold-up time T5

The Power Good Signal shall remain an up level for at least 10msec after AC power is removed and shall go to a down level before the 3.3V or +5V falls below their regulation limit.

4.6 Power OK (POK)

The power supply shall provide a “Power Good” signal to reset system logic, indicate proper operation of the power supply, and give advance warning of impending loss of regulation at turn off.

The electrical characteristics for the Power OK output driver are shown below:

Table6. Power OK Signal Characteristics

Power OK Signal Characteristics	
Signal Type	+5V TTL Compatible
Logic Level Low	<0.4V while sinking 4mA

Logic Level High	Between 2.4V and 5V output while sourcing 200μA
High-State Output Impedance	1kΩ from output to common

4.7 PS_ON

PS_ON is an active low, +5V tolerant TTL signal that allow the motherboard to remotely control the power supply. An internal pull-up resistor inside the power supply shall provide a TTL high output logic level, once an AC input voltage has been applied to the power supply. The electrical characteristics for the PS_ON signal are shown below:

Table7. PS-ON Signal Characteristics

PS-ON Signal Characteristics		
Signal Description	Min	Max
Input Low Voltage	0.0V	0.8V
Input Low Current (Vin=0.4V)	-	-1.6mA
Input High Voltage (Iin=-200μA)	2.0V	
VIH open circuit	-	5.25V

5.0 Auxiliary 5V Output:

The 5V auxiliary output will be active and in regulation whenever an AC input within the specified operating range is applied to the power supply input. The PS_ON pin of P1 will not affect the 5V auxiliary output.

6.0 Environment:

6.1 Operating ambient:

Table8. Operating ambient

Air Temperature	0 to 50 degrees centigrade
Relative Humidity	5 to 85 percent, non-condensing

6.2 Shipping and Storage:

Table9. Shipping and Storage

Air Temperature	-40 to 55 degrees centigrade
Relative Humidity	5 to 95 percent, including condensation

6.3 Altitude:

Operating To 5000 meters(16,400 ft)
Non-operating To 15250 meters (50,000 ft).

6.4 Cooling:

The power supply shall provide forced air cooling for the host system.

7.0 Safety and EMC**7.1 SAFETY REQUIREMENTS AND Certify**

The power supply has been certified by CCC. The CCC Safety mark shall appear on the product.

7.2 Conducted and Radiated Emissions:

Conducted and radiated emissions of the power supply shall comply with the requirements of GB9254 & EN55022 Class B.

7.3 ESD:

ESD of the power supply shall comply with the requirements of IEC61000-4-2 Level 3.

7.4 EFT:

EFT of the power supply shall comply with the requirements of IEC61000-4-4 Level 3.

7.5 Surge Susceptibility:

Surge Susceptibility of the power supply shall comply with the requirements of IEC61000-4-5 Level 3.

7.6 Hi-Pot:

Input to GND : Voltage 1500VAC Time 3.0S, Cut off current 10mA MAX

7.7 Grounding Continuity Test: 100mΩ MAX at 25.0A .**7.8 Ground Leakage Current:**

0.5mA MAX. AT 264V 50Hz

8.0 Mechanical:**8.1 Mechanical outline& DC wire drawing:**

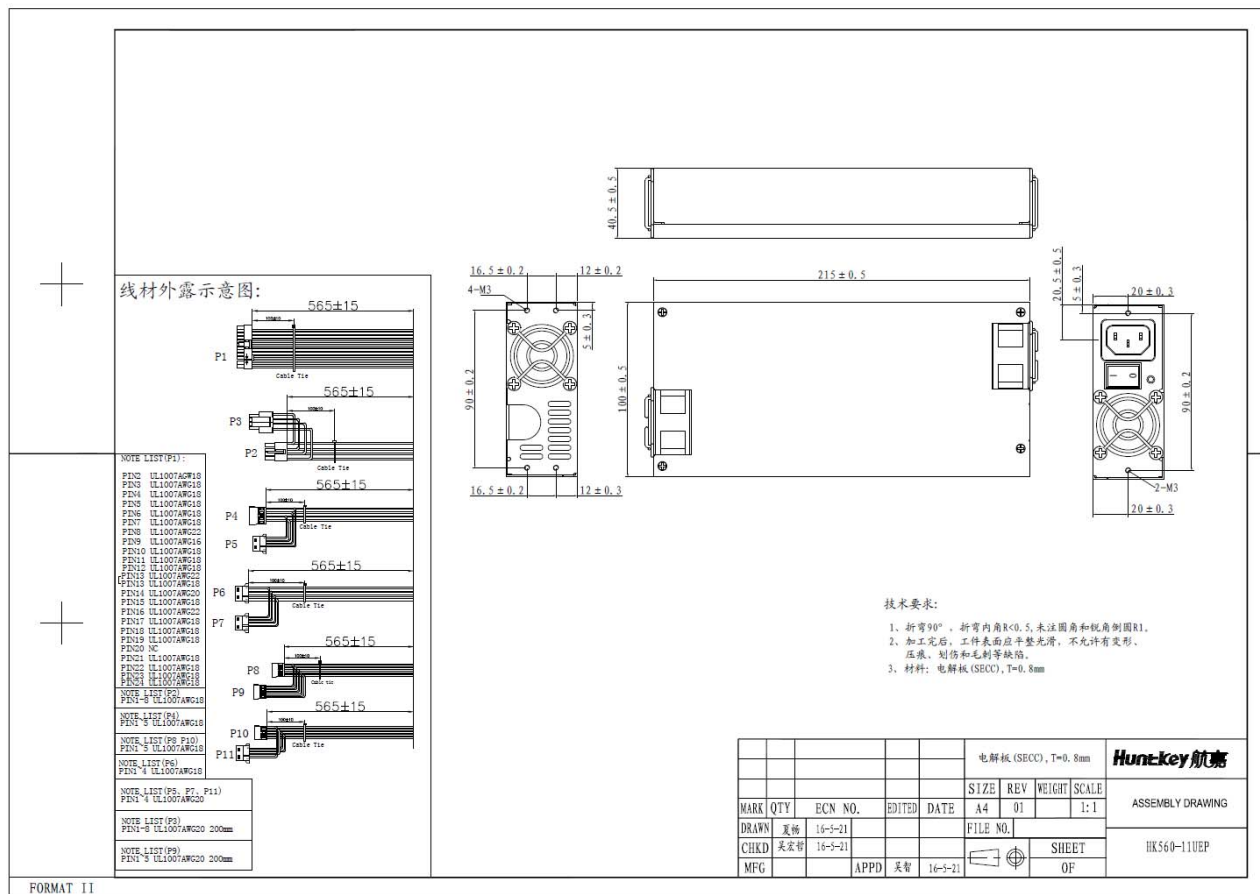

8.2 Label drawing

		型号: HK560-11UEP 交流输入: 100-240V~, 50-60Hz, 7-4A
SWITCHING POWER SUPPLY		开关电源
直流输出: +12V=38A (黄色), +5V= 20A (红色), +3.3V=15A (橙色), PG (灰色) -12V=0.5A (蓝色), +5VSB=3A (紫色), PS-ON (绿色) 额定功率: 460W, +5V&+3.3V联合输出功率: 140W		
警告	非专业维修人员请勿自行开启此盖!	
		
		
		
深圳市航嘉驰源电气股份有限公司		
Http://www.huntkey.com		REV: 00

Huntkey Hong Kong Development Co. Ltd.		File No. :
		Version :
Prepare by	Check by	Approved by
Wei Jun Deng	LieYang Zhao	Zhi Wu
Date:	2018.04.03	