



1.....	SCOPE/概述	4
2.....	Input Characteristics/输入特性	4
3.....	Output Characteristics/输出特性	5
4.....	Protection Requirements/保护要求	6
5.....	Environment Requirements/环境要求	7
6.....	Reliability Requirements/可靠性要求	7
7.....	EMI/EMS Standards/EMI/EMS 标准	8
8.....	Safety Standards/安规标准	8
9.....	Mach. Outline Drawing/外观图	9
10.....	Package Drawing/包装示意图	10

## 1. SCOPE/概述

The document details the electrical, mechanical and environmental specifications of a SMPS, the power supply provides 120 W continuous output power.

资料详细描述了一款 120 W(连续输出功率)开关电源的电气性,结构性及环境等要求.

The power supply shall meet the RoHS requirements.

此款电源符合 RoHS 要求.

### 1.1. Description/描述:

- SMPS Adaptor(Wall mount)/插墙式适配器       SMPS Adaptor(Desk-top)/桌面型适配器  
 Open Frame/开放式结构       SMPS Unit (With Case)/带铁壳型  
 Others/其他

## 2. Input Characteristics/输入特性

### 2.1. Input Voltage /输入电压

The range of input voltage is from 90Vac to 264Vac with a single phase.

输入电压范围: 从 90Vac 到 264Vac, 单相输入.

	Minimum/最小	Rating/额定值	Maximum/最大
Input Voltage/输入电压	90Vac	100Vac~240Vac	264Vac
Input Frequency/输入频率	47Hz	60Hz/50Hz	63Hz

### 2.2. Input AC Current/输入交流电流

2Amax. @ 100Vac~240Vac input & Full load/在 100Vac~240Vac 输入和满载条件下最大 2A

### 2.3. AC Receptacle/交流输入插座

The inlet receptacle shall comply with IEC 320 standard sheet C6(3 pin inlet) be certified Recognized or approved by CSA, UL, VDE.

输入交流插座符合 IEC 320 规范 C6 要求(3 pin 梅花座), 满足 CSA、UL、VDE 安规认证要求.

### 2.4. Inrush Current (cold start)/浪涌电流(冷启动)

Power supply inrush current shall be less than the ratings of its critical components (including rectifiers, fuses, and other surge limiting device) under all conditions of line voltage of Section 2.1.

在 2.1 中所有输入条件下，浪涌电流应小于关键器件的额定值(包括整流桥、保险丝和其他浪涌限制元件)

## 2.5. Efficiency /效率

While input 220Vac, the efficiency is more than 88% with max load

在输入 220Vac，满载条件下，效率不小于 88%

## 2.6. Power Saving / 输入空载功率损耗

AC Input	DC Output	Loading	Input Power
115Vac/230Vac	19V	0A	<0.5W

## 3. Output Characteristics/输出特性

### 3.1. Static Output Characteristics <Vo & R+N>/静态输出特性<输出&纹波+噪音>

Output Rating	Rated Load/额定负载		Peak Load	Output Range 输出电压范围	R+N 纹波与噪声	Remark 备注
	Min. Load	Max. Load				
+19V	0 A	6.32A	/	18.05V ~ 19.95V	380mVp-p	

Ripple & Noise: Tested by a oscilloscope using 20MHz bandwidth and the output is paralleled a 0.01uF ceramic capacitor and a 10uF electrolysis capacitor. (Under the input Voltage 100~240Vac)  
纹波与噪声：量测时示波器选用 20MHz 带宽限制,输出端要并联一颗 0.01uF 的陶瓷电容和一颗 10uF 的电解电容(输入电压 100~240Vac)

### 3.2. Line/ Load Regulation/线性/负载调整率

Output Rating	Load Condition/负载条件		Line Regulation 线性调整率	Load Regulation 负载调整率	Remark 备注
	Min. Load	Max. Load			
+19V	0 A	6.32A	± 1%	± 5%	

### 3.3. Turn - on Delay Time/开机延迟时间

3S max. @ 90Vac input & Full load/在 90Vac 输入和满载条件下最大 3S

### 3.4. Hold-up Time/关机维持时间

10mS min. @ Full load & 100Vac/60Hz input turn off at worst case

在 100Vac 输入,满载同时最差情况下关机，最小 10mS。

### 3.5. Rise Time/上升时间

50mS max. @ Full load/在满载条件下最大 50mS。

### 3.6. Overshoot / Undershoot 过冲

Any overshoot / undershoot at turn on or turn off of AC input, output shall be within  $19V \pm 10\%$ .  
电源开关机任何过冲必须满足  $19V \pm 10\%$ 。

### 3.7. Output Load Transient Response/输出负载瞬态响应

Output voltage is within  $19V \pm 5\%$  while the load step is from 0 to 50% and from 50% to 100% of max load, S/R: 1A/us, frequency: 100Hz and 1KHz, output capacitance loading: 1000uF  
输出电压保持在  $19V \pm 5\%$  之间,负载变化: 从 0 到 50%; 50% 到 100%, 斜率: 1A/uS,频率: 100Hz; 1KHz, 输出带 1000uF 电容。

### 3.8. Capacitance Load/容性负载

While input 90Vac and capacitance load is 1000uF, the adapter can turn on normally and the output is in the rated range.  
在输入 90Vac, 1000uF 容性负载条件下, 适配器能正常开机, 并且输出电压范围在额定范围内。

## 4. Protection Requirements/保护要求

### 4.1. Over Power Protection/过功率保护

When an output power over 120%~180% rated load, the power supply shall shut down and enter auto-recovery mode.  
当输出功率超过额定功率的 120%~180%时, 产品输出进入打嗝模式。

### 4.2. Short Circuit Protection/短路保护

When an internal fault occurs, or an external fault is applied to the power supply, such that an overload or short circuit is applied to the output, the power supply shall shut down and enter auto-recovery mode.  
当输出对地短路时,产品输出将进入自锁模式,当短路情况解除后,产品将会恢复正常。

### 4.3. Over Voltage Protection/过压保护

The adapter will latch off that means no output while over voltage happened at output terminal that caused by internal fault, the output trip voltage will be excess than 29V, remove AC input, the

adapter will be return to normal by AC reset after 10 seconds.

当输出过压超过 29V 时, 输出将锁死, 交流断电 10s 后再上电, 产品将会恢复正常。

## 5. Environment Requirements/环境要求

### 5.1. Operating Temperature and Relative Humidity/操作温度和湿度要求

0°C to +40°C

10%RH to 90%RH

### 5.2. Storage Temperature and Relative Humidity/存储温度和湿度要求

-20°C to +80°C

5%RH to 95%RH (non-condensing) @ Sea level shall below 10,000 feet

在海拔低于 10,000 英尺的条件下, 低温存储下限为-20°C (无结冰环境); 高温存储上限为 +80°C, 相对湿度为 5%RH to 95%RH。

### 5.3. Vibration/振动

10 to 300Hz sweep at a constant acceleration of 1.0G (Breadth: 3.5mm) for 1Hour for each of the perpendicular axes X, Y, Z

扫描频率: 10 to 300Hz, 加速度: 1.0G(位移: 3.5mm), X, Y, Z 三垂直坐标轴向各振动 1 小时

### 5.4. Drop in/跌落

1 Corner, 3 Edges, 6 Surfaces each once. Drop on the cement plane, Height: 75cm.

1 个角, 3 个边, 和 6 个面各 1 次, 跌落高度: 75 厘米, 跌落到水泥地板上。

## 6. Reliability Requirements/可靠性要求

### 6.1. Burn-in/老化

The failure rate must be defined at 35 degrees centigrade ambient temperature, sea level, 220 Vac, and 100 percent of output load the failure rate must be less than 0.50% per 1000 hours.

在 220V 满载输出, 35°C 环境下老化 1000 小时. 失效必须小于 0.5%

## 7. EMI/EMS Standards/EMI/EMS 标准

### 7.1. EMI Standards/EMI 标准

EN 55022:1998, +A1:2000 +A2:2003, Class B
CISPR 22:2003, Class B
AS/NZS CISPR 22: 2004, Class B
The products are <b>3dB</b> below the limit using the non-central T distribution for EMI and the noise measurement is defined as Q-peak hold mode

### 7.2. EMS Standards/EMS 标准

EN 61000-3-2	Harmonic current emissions
EN 61000-3-3	Voltage fluctuations & flicker
EN 61000-4-2	Electrostatic Discharge(ESD): 15KV air discharge, 8KV contact discharge
EN 61000-4-4	Electrical Fast Transient/Burst-EFT
EN 61000-4-5	Surge Immunity Test: AC Power Line: line to line 1KV,line to earth 2KV

## 8. Safety Standards/安规标准

### 8.1. Dielectric Strength(Hi-pot)/介电耐压强度(高压)

Primary to Secondary: 1500Vac / 10mA / 60 seconds (3 seconds for production)

初级对次级: 1500Vac / 10mA / 60 秒(量产高压测试时间: 3 秒)

### 8.2. Leakage Current/漏电流

0.25mAmax. at 264Vac / 50Hz input/在输入 264Vac/50Hz 的条件下最大 0.25mA

### 8.3. Regulatory Standards/安规标准

Type	Country	Standard	Type	Country	Standard
<input type="checkbox"/> UL/CUL	USA	UL60950-1	<input type="checkbox"/> PSB	Singapore	IEC60950-1
<input type="checkbox"/> TUV	Europe	EN60950-1	<input checked="" type="checkbox"/> PSE	Japan	J60950
<input checked="" type="checkbox"/> CCC	China	GB4943	<input type="checkbox"/> NOM	Mexico	NOM-001
<input type="checkbox"/> CE	Europe	EN60950-1	<input type="checkbox"/> GOST	Russia	MEK60950

## 9. Mach. Outline Drawing/外观图

### 9.1. 机壳图

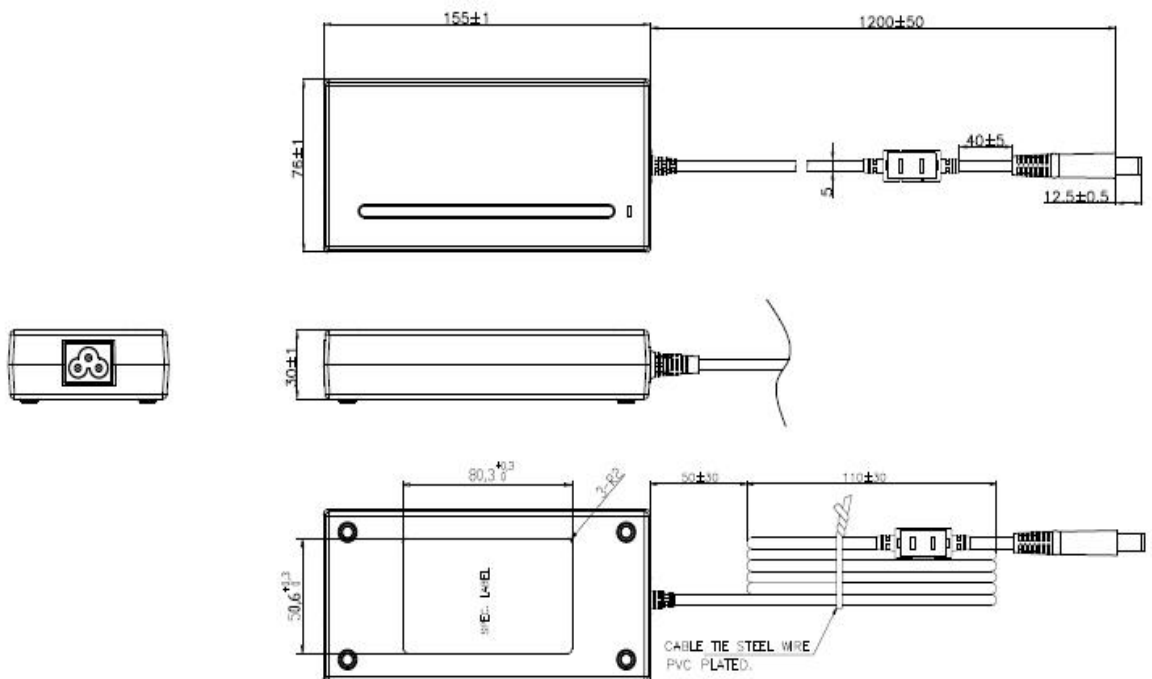

### 9.2. 标贴图